



5000 Series

Standard Indicators



T51XW Indicator



T51P Indicator

Multifunctional Indicators for Demanding Industrial Applications

The OHAUS 5000 series of multifunctional indicators is ideal for a range of applications in production, packaging, warehouse, inventory, shipping and receiving areas. Ideal for bench and floor scale use, the 5000 series is available in both a dry-use, ABS plastic housing as well as a NEMA4X/IP66 water resistant stainless steel housing. Both housings feature large, bright backlit displays, raised tactile keys, battery-powered use (optional on T51XW), and are easy set-up and use. The 5000 series is the solution to your weighing indicator applications that require multiple functions, rugged construction, comprehensive yet intuitive software and multiple connectivity options.

Standard Features Include:

- T51P features a high-impact, durable ABS plastic housing with reversible rear cover for either wall, column, scale front, or table-top mounting
- T51XW features an NEMA 4X/IP66 water resistant stainless steel housing with integral faceplate supports for easy servicing.
- 1:30,000 maximum displayed weighing resolution with temporary display of 10x readability in weighing mode using quick key press
- 1:10,000 NTEP certified / Measurement Canada approved resolution
- Quick display of results using large LCD with high-contrast white backlight
- Easy to operate with 4-key membrane keypad with raised tactile keys
- Weighs in one or more units: kg, g, lb, oz, lb:oz (decimal), metric tonnes and user-definable custom unit
- Multiple weighing modes including Counting, Percent Weighing, Dynamic/Animal Weighing, Checkweighing, and Display Hold
- T51XW includes an internal universal switching power supply with hardwired line cord, T51P has the same internal power supply with universal line cord or can be powered using 6 "C" batteries (80 hour battery life) – Optional NiMH internal rechargeable power pack available for both indicators
- Includes RS232 interface with GMP/GLP data output including date and time
- Optional interfaces include DC relay control kit, AC relay control kit, 2nd RS232 and RS485/422

5000 Series Standard Indicators

5000 Series Indicators Offer Multiple Features and Easy Configuration:

To meet different operational needs, the 5000 Series includes a suite of configurable software:

- Counting mode for packaging and inventory control, enabling counting into a container or out of a container for bulk operations. Supports a maximum displayed counting resolution to 1:300,000 (minimum APW equal to 0.1d), selectable auto-optimization of average piece weight (APW). APW data can be displayed at any time by a quick key press.
- Percent Weighing mode for formulation and mixing applications, with display of reference weight with a quick key press.
- Dynamic/Animal Weighing with selectable weigh times from 0-60 seconds
- Checkweighing function for packaging and weight checking, with display of results using LCD display and red/yellow/green LEDs. Audible beeper can be configured to prompt when weight is within range, under, over, or under/ over range. Target weight values can be displayed at any time using a quick key press.
- Display Hold mode for weighing large packages holds last stable weight on display until cleared
- The 5000 Series weighs in one or more user-selectable units: kg, g, lb, oz, lb:oz (decimal), metric tonnes and user-definable custom unit
- Supports GMP/GLP data output with date, time user ID, project ID and scale ID. The 5000 Series features selectable print options for data and print format
- To limit operator access to functions, the 5000 Series offers both software lockouts for menu items as well as individual key functions.

Options and Accessories

Interface Options

	OHAUS Number
AC Relay Kit, T51P/T51XW	80500720
DC Relay Kit, T51P/T51XW	80500727
RS485/422 Interface Kit, T51P/T51XW	80500731
RS232 Interface Kit, T51P/T51XW	80500733
Foot Switch	71173378

Power Options

Rechargeable Battery Kit, T51P/T51XW	80500729
--	----------

Mounting Accessories

Wall Mount Kit, T51P	72200227
Wall Mount Kit, T51XW	80500735
Base Mount Kit, T51P	80500722
Column Mount Kit, 35cm, painted, T51	80500723
Column Mount Kit, 68cm, painted, T51	80500724
Column Mount Kit, 35cm, stainless steel, T51	80500725

Mounting Accessories (continued)

	OHAUS Number
Column Mount Kit, 68cm, stainless steel, T51	80500726

Compatible with all existing columns for Champs and CD/CW11/CD31/33/CKW indicators

Other Accessories

Compact Dot Matrix Impact Printer	80252042
Compact Thermal Printer	80251992
OHAUS Collect Software	80500746
TAL Software WinWedge	SW12W
Paper for Printer, 80252042 (1 roll)	80251932
Ribbon for Printer, 80252042	80251933
RS232 Cable & Adapter, 80252042 Printer to T51XW	80252574
RS232 Cable, PC 9 Pin to T51XW	80500552
RS232 Cable, PC 25-pin to T51XW	80500553
RS232 Cable & Adapter, 80252042 Printer to T51P	80252571
RS232 Cable, PC 9-pin to T51P	80500525
RS232 Cable, PC 25-pin to T51P	80500524

Outline Dimensions

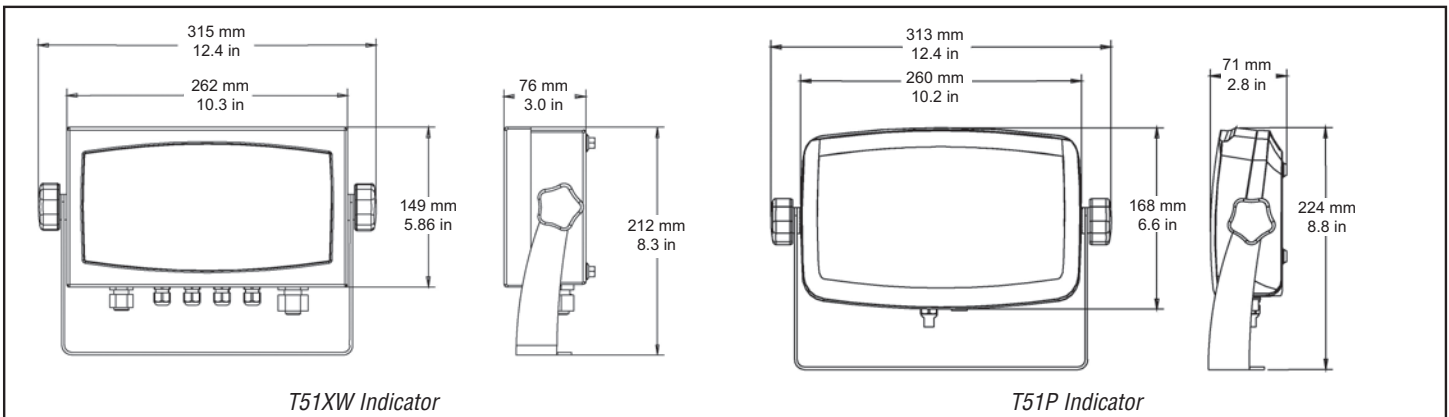

Standard Features:

Optional NiMH Battery

Allows for use in environments where an electrical outlet may not be readily available

Internal Slot for Capacity Label

Protects label from the effects of moisture and external environments

Stainless Steel 304 NEMA 4X/IP66 Enclosure

Indoor/outdoor protection against falling dirt, rain, sleet, snow, windblown dust, splashing and corrosion



3-Color LED Checkweigh Indication

with configurable beeper alert

High-Visibility LCD Display

with bright white LED backlight. Fast display stable weight within 2 seconds

Included Table/Wall Mount Bracket

With large ergonomic adjustable knobs to maximize viewing angles

Hinged Front Cover

Only four sealing screws secure the housing for ease of servicing, while still ensuring IP66 seal integrity



One-Key, Multiple Mode Selection

Counting, Dynamic Weighing, Display Hold, Percent Weighing and Checkweighing

Universal Switching Power Supply

Automatically adapts to different voltages from 100-240 VAC; plug anywhere, anytime

Stay Connected

Built in RS232 bi-directional interface and built-in external input, optional RS422/485, optional second RS232 and optional AC or DC relay

Simple Plug-In Battery Installation

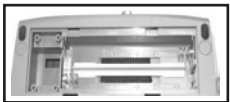

Use six C- alkaline batteries or the optional NiMH battery

High-Visibility LCD Display

with bright white LED backlight and fast display stable weight within 2 seconds

Internal Slot for Capacity Label

Protects label from the effects of moisture and external environments

3-Color LED Checkweigh Indication

with configurable beeper alert

Included Table/Wall Mount Bracket

With large ergonomic adjustable knobs to maximize viewing angles. A ratchet-type angle adjustment with metal inserts ensure that viewing

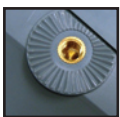

angles are set securely, and lasts a long time even with frequent adjustments

Reversible Rear Housing

Cables can exit above (table or front scale mounting) or below (wall or bench scale mounting) for convenient mounting. Front scale mounting with available accessory. Internal structural ribs provide strength and minimize flexing.

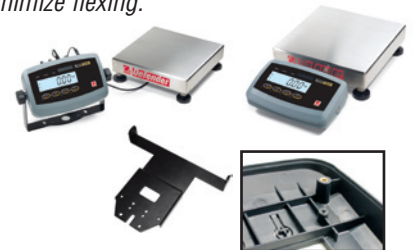

Universal Switching Power Supply

100-240 VAC with AC line cord; no need for an external AC adapter!

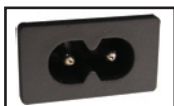

Stay Connected

Built in RS232 bi-directional interface and external input, optional RS485/422, optional second RS232 and optional AC or DC relay

One-Key, Multiple Mode Selection

Counting, Dynamic Weighing, Display Hold, Percent Weighing and Checkweighing

5000 Series Standard Indicators

Specifications

Indicator Models	T51P	T51XW
Capacity Range	1 to 999,950 kg/lb	
Maximum Displayed Weighing Resolution	1:30,000	
Maximum Displayed Counting Resolution	1:300,000	
Certified/Approved Resolution	1:10,000	
Minimum Average Piece Weight (APW)	0.1d	
Weighing Units	kg, lb, g, oz, lb:oz, metric tonnes, custom unit	
Modes	Static Weighing, Dynamic Weighing, Counting, Checkweighing, Percent Weighing, Display Hold	
Housing	ABS plastic with internal reinforcing ribs	304 stainless steel enclosure
Display	6-digit, 7-segment LCD, 25mm/1 inch high digits, with high-contrast white LED backlight	
Checkweigh Indication	3-color checkweigh LED with configurable beeper signal	
Keypad	4 function membrane switches, raised tactile keys	
Ingress Protection	—	NEMA 4X / IP66
Load Cell Excitation Voltage	5V DC	
Load Cell Drive	Up to 8 x 350 ohm Load Cells	
Load Cell Input Sensitivity	Up to 3 mV/V	
Stabilization Time	Within 2 seconds	
Auto-Zero Tracking	Off, 0.5, 1 or 3d	
Zeroing Range	2% or 100% of capacity	
Span Calibration	1 kg/lb to 100% of capacity	
Interface	Built-in RS232 and External Tare Input included Optional 2nd RS232, RS422/485, AC Relay or DC Relay available	
Overall Dimensions (inc. bracket) (W x D x H)	10.2 x 2.7 x 8.8 in / 260 x 71 x 224 mm	10.3 x 3 x 8.7 in / 262 x 76 x 212 mm
Enclosure Dimensions (W x D x H)	10.2 x 2.7 x 6.6 in / 260 x 71 x 168 mm	10.3 x 3 x 5.8 in / 262 x 76 x 149 mm
Net Weight	3.3 lb / 1.5 kg	7.7 lb / 3.5 kg
Shipping Weight	5.0 lb / 2.3 kg	9.5 lb / 4.3 kg
Shipping Dimensions (W x D x H)	13 x 9.5 x 7 in / 330 x 240 x 180 mm	
Operating Temperature Range	14°F to 104°F / -10°C to 40°C	
Relative Humidity Range	Maximum 80% up to 88°F/31°C, decreasing linearly to 50% at 104°F/40°C	
Power	100-240 VAC / 50-60 Hz Internal universal power supply, line cord 6 'C' cell batteries (not supplied) with 80 hour life Opt. Int. rechargeable NiMH battery (30-hr. typical operation)	100-240 VAC / 50-60 Hz Internal universal power supply, hardwire cord Opt. Int. rechargeable NiMH battery (30-hr. typical operation)

Features

T51P: ABS plastic housing with internal rib reinforcements, reversible rear cover, backlit LCD weight display, checkweighing indication (green, yellow, red), membrane keypad with raised tactile keys, built-in bi-directional RS232 with manual/continuous/interval printing, external tare input, hardware configuration lockout switch, internal switching power supply with line cord and battery power using 6 "C" cell batteries.

T51XW: Stainless steel water resistant NEMA 4X / IP66 housing, integral faceplate supports for easy servicing, backlit LCD weight display, checkweighing indication (green, yellow, red), membrane keypad with raised tactile keys, built-in bi-directional RS232 with manual/continuous/interval printing, external tare input, hardware configuration lockout switch, internal switching power supply with hardwired cord.

Options and Accessories

Internal rechargeable NiMH battery pack, 2nd RS232 interface, RS485/422 interface, AC Relay or DC Relay, column mount kits, scale front mount bracket, interface cables, printer.

Other Features

Zero point calibration, calibration test, span or linear calibration, selectable auto-zero tracking range, selectable stability range, selectable averaging level, selectable LCD backlight, selectable auto shutoff, retain zero weight data after power-off, Geo gravity adjustment, selectable key beep, key function lock, menu lock, selectable power-on and calibration unit, battery status display, display of gross/net weight, indication of stability, center of zero, over- and underweight, overload and underload conditions. Configuration menus for PRINT1, PRINT2, COM1, COM2, and I/O.

Compliance

- **Legal-for-Trade:** NTEP (CC No. 08-039), Measurement Canada (Approval No. AM-5687)
- **Safety and EMC:** UL_{US} 2005/95/EC low voltage directive: EN60950-1:2001, FCC Part 15 Class A 2004/108/EC EMC directive: EN61326-1:1997; +A1:1998; +A2:2001; +A3>2003
- **Other:** Compliant to Directive 2002/96/EC on waste electrical and electronic equipment (WEEE)
- **Quality:** OHAUS quality management system registered to ISO 9001:2008

OHAUS CORPORATION

* 19A Chapin Road
P.O. Box 2033
Pine Brook, NJ 07058 USA

Tel: 800.672.7722
973.377.9000
Fax: 973.944.7177

www.ohaus.com

With offices throughout Europe,
Asia, and Latin America

* ISO 9001
Registered Quality Management System

